

# *hills café* / *SPACE*

Introduction to Mori Building Facilities for Events and Advertising

Tokyo City View



Sky Deck

Hills Café/Space



Mori Arts Center Gallery



Grand Hyatt Tokyo



Roppongi Hills Club



O-yane Plaza

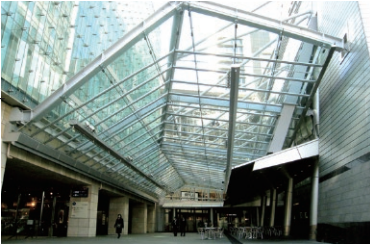

Roppongi Academyhills



Roppongi Hills Arena



TOHO Cinemas Roppongi

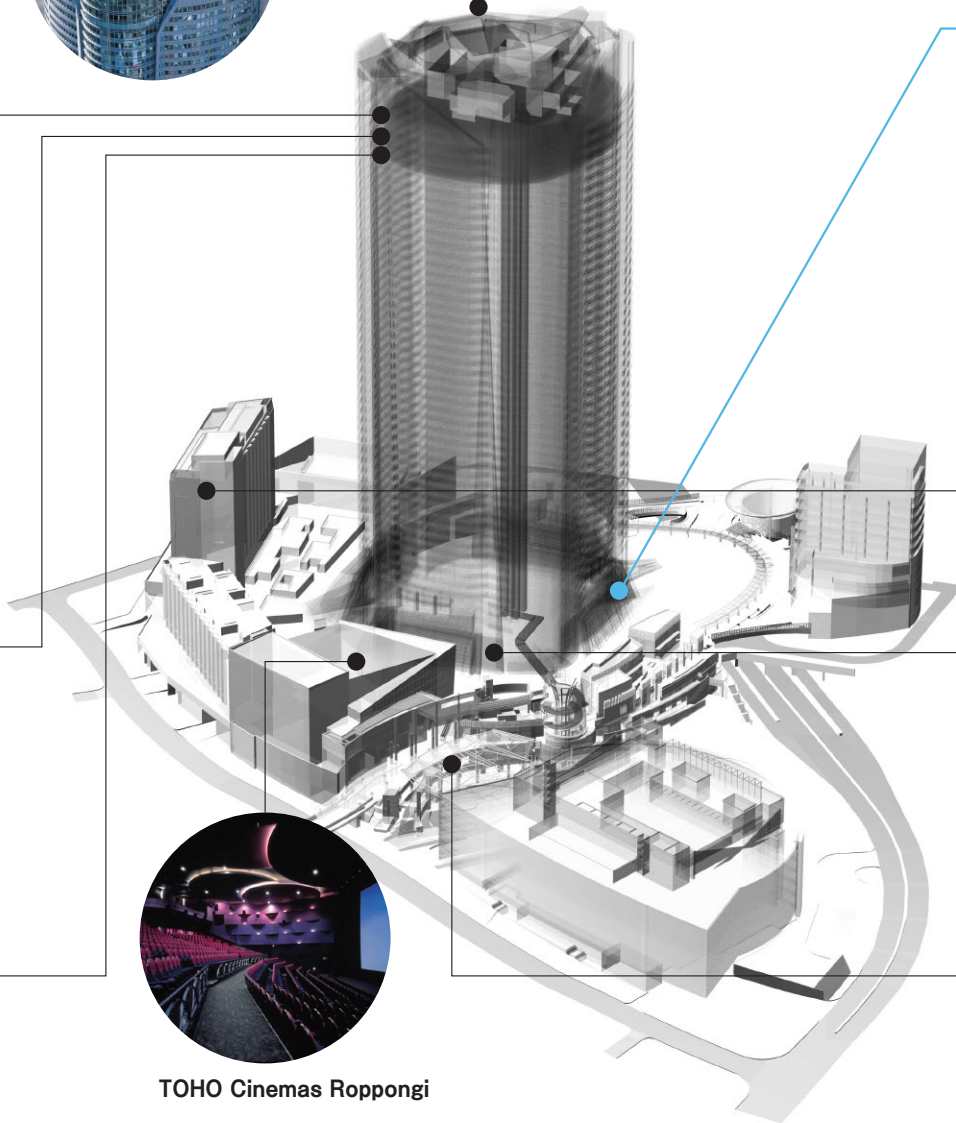

## Hills Café/Space

### Located on a major artery for visitors to Roppongi Hills Café/Space

Hills Café/Space is ideally located in the heart of Roppongi Hills, along the Art Walk, the complex's primary artery that extends from Metro Hat (Roppongi Station, Hibiya Line) to the Residences, linking the town from north to south. Art Walk offers access to cultural facilities like the Mori Art Museum, the Tokyo City View (observation deck), Academyhills and the members-only Roppongi Hills Club, as well as the entrance to the TOHO Cinemas. This bustling area is one of Roppongi Hill's key locations.

The lively Art Walk draws crowds in, and they soon find themselves on the path that leads to the bright, constantly-changing ambience of the Hills Café/Space.

The venue is a spacious 290m<sup>2</sup>, with ceilings soaring 3.3m, a wide entryway, and wood-grain floors that show off the pure white walls. The space is ready to be used for everything from events for clients and the press, to parties, art displays and small live performances, and exhibitions.



Hills Café/Space



## Hills Café/Space Features



- Direct access to Roppongi Station on the Hibiya Line.
- An ideal location on one of the main arteries through Roppongi Hills, which attracts 100,000 visitors on weekdays and 130,000 on weekends and holidays.
- A multi-purpose space area of 220m<sup>2</sup>. Maximum seating capacity of 155, or up to 200 standing.
- Handles a wide variety of uses, from exhibits, presentations and parties, to press conferences and café concepts that make full use of the space's café functionality.
- Spatial design that provides a high-level balance between function and an ambience suitable to Roppongi Hills.
- A basic interior design that can be arranged to suit almost any kind of event.
- Can be used to provide a client with an originally-branded café within Roppongi Hills.
- Can also be used for a range of promotional purposes, with staff dressed in appropriate logo wear, etc.
- Original food and beverage items can be provided in line with a specific client's image.
- Linkage with Metro Hat and the unique "waterscape" media features of Roppongi Hills can provide even more effective branding and a more powerful product message.

## Space for lease



Total floor area of inside the shop: Approx. 290m<sup>2</sup>

Effective area for an event: Approx. 220m<sup>2</sup>

Floors: Wood flooring (It is possible to affix a sheet)

Walls: White paint (Please consult with us about affixing a sheet)



## Public Area

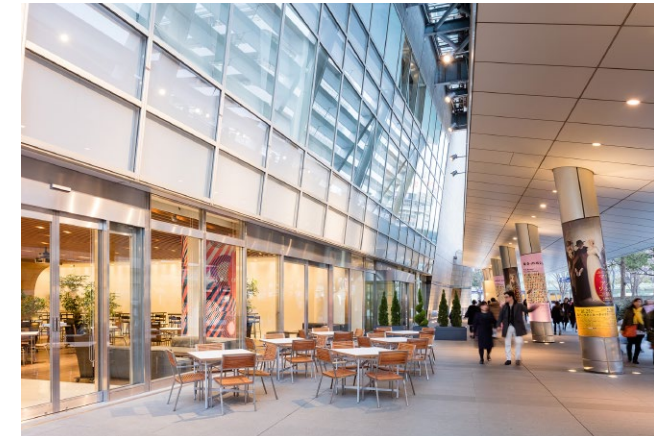

  
Please note that in this area no walls, stages, or other displays are allowed as the staff use this area as an access route.

  
Please note that in this area no walls, stages, or other displays are allowed as this is designated as an emergency escape route.

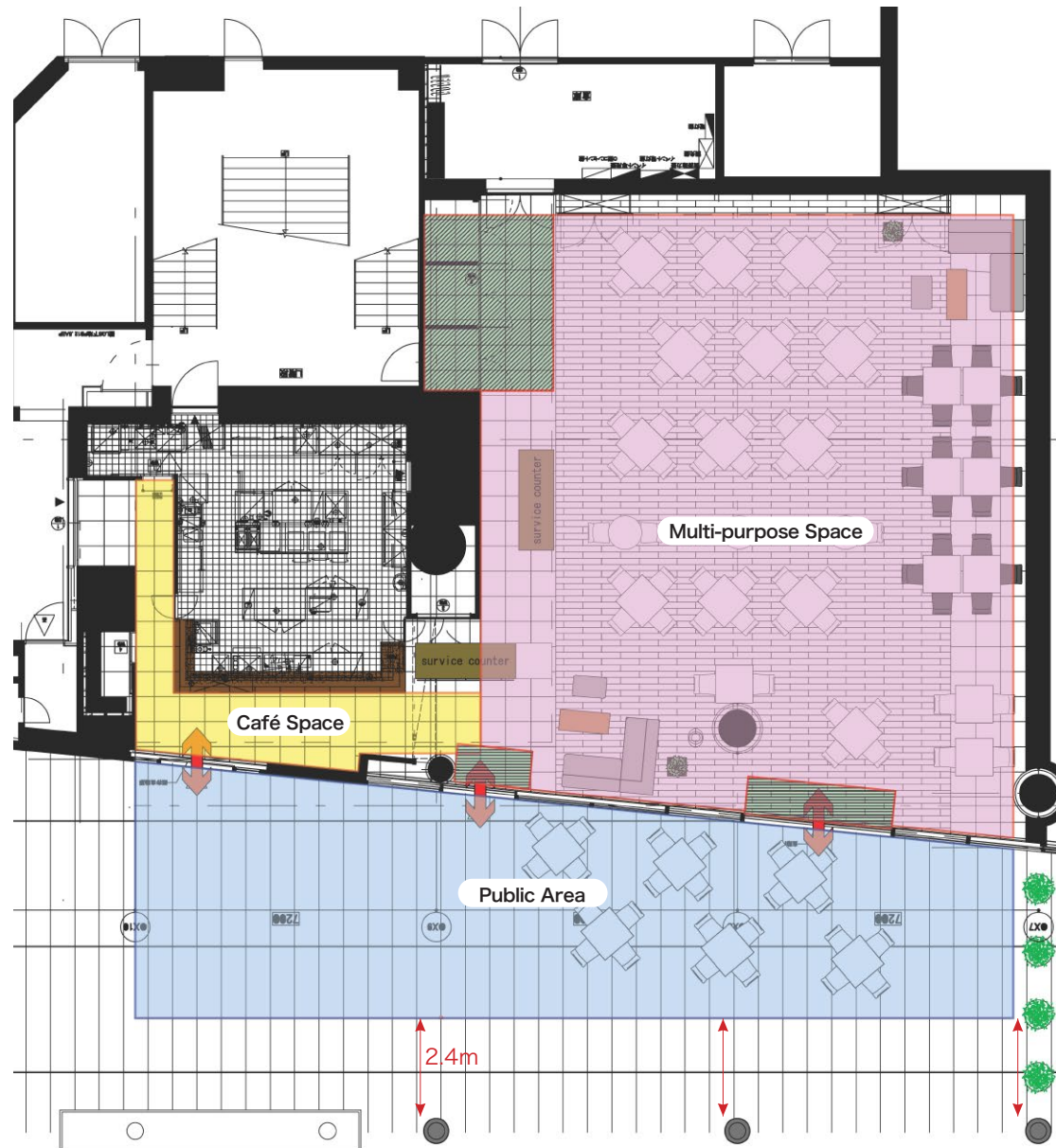

Condition for use of public area:

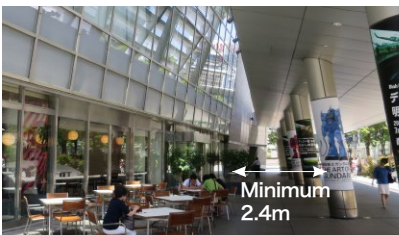

\* Secure sufficient walkway space for pedestrians.

\* Adjustment required for the content of event including installed objects

**Area •Facilities**

Total floor area of inside the shop:  
Approx. 290㎡  
Effective area for an event: Approx. 220㎡

Ceiling height:3.2m

Maximum seating for 155,  
Standing capacity 200 people

**Specifications**

Floors: Wood flooring

Walls: White paint

Ceiling: Wood-grain louvers, white paint

Load limit: 300kg/㎡

Basic hours: 8:00 a.m.-11:00 p.m.

**Equipment**

Power source

20A per circuit

(15A parallel circuit/2-plug outlets),  
4 circuits, outlets at 10 locations

**Lighting**

Recessed lights: 137

Spotlights: 84

Multifunctional LED indirect lighting

**Sound system**

Ceiling/floor speaker system,

Mixer, multi-switcher, DVD/CD player,  
Wired/wireless microphones, mic stand

**Others**

Projector, LAN, TV antenna,

Phone line, picture-hanging rails, chairs,  
tables

**CONTACT**

Sales Planning Group,

Town Management Department

TEL : 03-6406-6666

### Café Exterior Decoration

The café exterior may also be decorated when using the Hills Café/Space. Use of the exterior for displaying the café name and/or theme is welcome.

Use of café is conditional upon returning the space to its original condition.

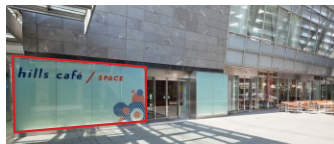

▼ G.L.

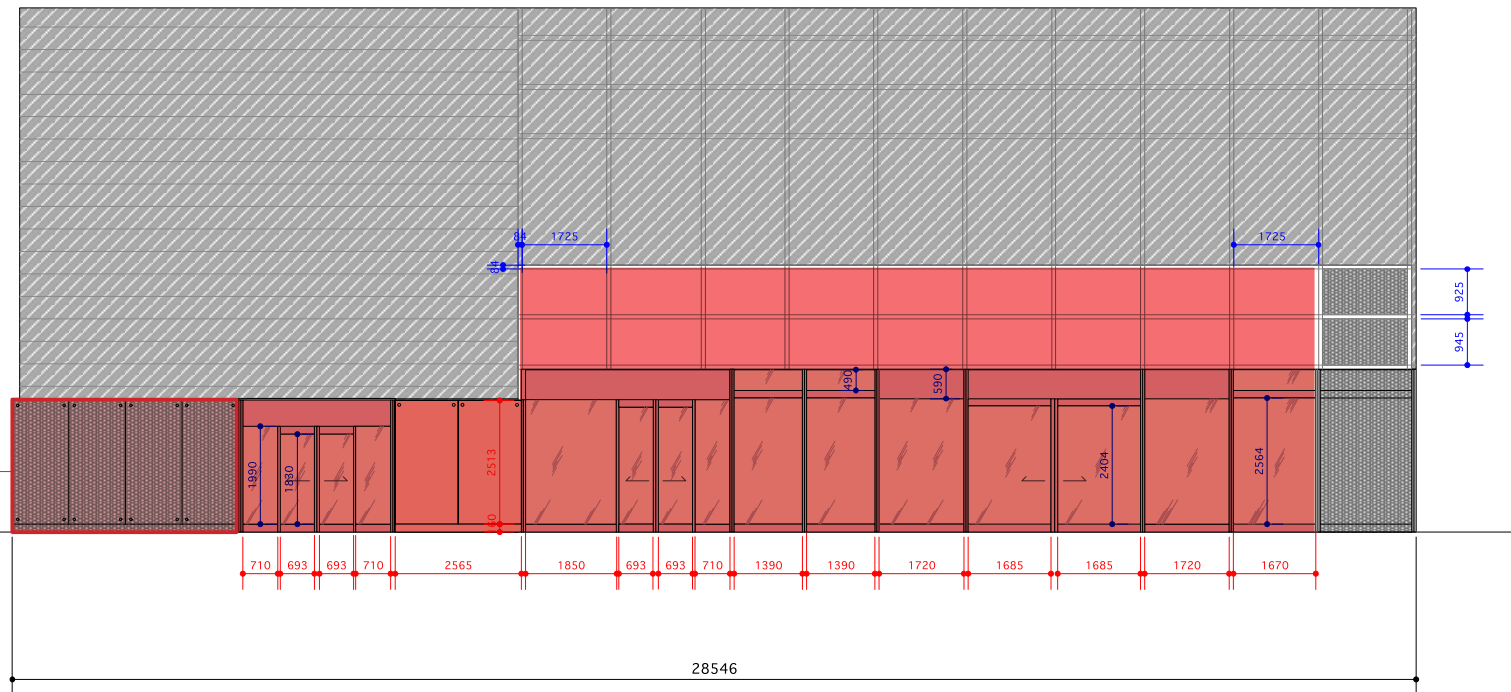

\*Assumes signage and decoration designed for café use.  
 \*Posting of pure ads, etc. may require applying for outdoor advertising.

### Usage Examples





\* Pictures shown were taken during events held in the past. Details for future events are to be decided at the time of the event.

Details	Day of Use	Usage Hours	Fee (tax excluded)
<b>Basic Fees</b>	weekdays	8:00~23:00	¥800,000/Day
	Saturday/Sunday/Public Holiday	8:00~23:00	¥1,200,000/Day
<p>* Actual expenses will be incurred separately for the content of event which requires more than normal operation for drinking and eating.            * Normal operation for drinking and eating refers to standard business of Hills café when not holding an event.</p>			
<b>Fee for nighttime unloading and preparation</b>	weekdays	23:00~8:00	25% of the basic fee for the initial day of the event
	Saturday/Sunday/Public Holiday	23:00~8:00	
<p>* If the initial day of the event falls on a weekend or holiday, 25% of the weekend/holiday fee will be charged regardless of whether set-up and nighttime unloading for set-up takes place on a weekday.            * Unloading and preparation at the venue may start after 11 p.m., once all customers have left and the venue has been secured.</p>			
<b>Fee for nighttime removal and loading</b>	weekdays	23:00~6:00	¥50,000/hour
	Saturday/Sunday/Public Holiday		
<b>Overtime extended fee</b>	weekdays	23:00~8:00	¥60,000/hour
	Saturday/Sunday/Public Holiday		
<b>Special Usage Fee</b> Multi-purpose Space	weekdays	8:00~23:00	¥400,000/Day
	Saturday/Sunday/Public Holiday	8:00~23:00	¥600,000/Day
<p>Full-day use for preparation and removal</p>			

\*The pricing above is valid as of July 2022, but as prices may fluctuate please consult with each individual vendor separately.



**Options**

**Custom menu**

Custom menu items can be provided at Hills Café/Space at the client’s request, given notification at least three weeks prior to the event.

Original Menu Development Fees

Drinks	From 10,000 yen/item
Desserts	From 20,000 yen/item
Food	From 30,000 yen/item

**Party Catering**

Catering can be provided during events at Hills Café/Space. Feel free to consult the venue regarding number of guests, budget and menu, etc.

Party Catering Fees

Estimate provided separately

**Boxed meals for staff**

Boxed meals can also be prepared for staff. For information regarding terms and conditions, please consult your event coordinator.

**Sales**

Product sales may also be conducted. Please consult your event coordinator for information regarding terms and conditions.

\*Clients are responsible for providing sales staff, cash register staff and management of products.

**Other equipment**

As a rule, fixtures, equipment, sound and lighting for events at Hills Café/Space are to be provided by the user.

**Custom menu images**



**Party catering images**



\*The pricing above is valid as of July 2022, but as prices may fluctuate please consult with each individual vendor separately.

● Lighting equipment list

Type		Quantity	Note	
General Lightning	Event area	Left and right white ceiling down light	25 Left 12 · Right 13	
		Front ceiling down light	9	
		Left and right upper wall down light	46 Left 23 · Right 23	
		Front wood grain ceiling	12 3 trips in 4 locations	
		Wiring duct spotlights	50 Can swing	
		Upper wall Philips Hue light strip	Total 3 Left-right front	
		Boundary	Ceiling down light	3
			Kitchen area	Upper wall down light
		Customer traffic area		12
		Down light above the counter		6
Pendant light above the counter	4			
Down light in the kitchen	16			
Total 62				
Power supply for events	Main capacity	30kVA	AC 1 φ 3 W 200/100 V 50 Hz	
	Master breaker	200A	BBW 3200 Z (with leakage alarm)	
	Load circuit (C type · 30 A)	12 circuit		
	Sending wiring to the ceiling of the venue (C type · 30 A)	21 lines	In the event board	
	Sending wiring to the floor of the venue (C type · 30 A)	4 lines	Replace with a load circuit to use	
	Branch breaker (for adding temporary distribution board) * Connect after master breaker	150A	BBW 31501	

Infrared wireless microphone	audio-technica ATIR-T22A	2	With switch
Microphone stands	K&M 21020B	2	Boom microphone stand (black)
	Panasonic WN-431	2	Straight microphone stand (silver)
Portable CD player	Panasonic SL-CT810	1	

● Visual equipment list

Type		Quantity	Note
Visual equipment	Projector	Panasonic PT-DX610L	1 Resolution:1024×768·6500lm
	Multi-switch	IDK MMS-4502	1
	DVD player	PIONEER DV-3030V	1

● Other venue facilities

Type		Quantity	Note
Other venue facilities	Hanging pole rack	Φ 50 mm · Fixed type · 1.2 m pitch	10 Load bearing capacity at any one point: 30 kg Total load capacity 200 kg (per bar)
	Outlet under the floor	Power supply	10 Distributed arrangement of 20 A · 4 circuits
		LAN	10 RJ-45 (female connector)
AV input		1 Visual: Mini D-sub 15 pin Sound: Stereo mini (female connector)	
Wall outlet	TV antenna	1 F type connector (U / V / BS / CS)	
	Power supply	2 20 A (parallel)	
Network	B FLETS Hikari	100Mbps	Common use of underfloor wired / wireless

● Sound equipment list

Type		Quantity	Note	
Sound equipment	Mixing desk	YAMAHA MG16XU	1 Mono 8ch, stereo 4 system	
	Floor speaker	JBL EON515	2 Amplifier built-in · stand equipped	
	Ceiling speaker	TANNOY I5AW	12	Event area
		BOSE FS16W	4	Kitchen area
	Amplifier	TOA P-120DH	1	Using 1 channel in each of the above two areas
	Storefront signboard built-in speaker	Custom order		
	Amplifier	Amcron XLS402	1	
	Wired microphone	SHURE SM48S-LC	2	With switch

Please use the specified form in the design of the layout of the event. If you intend to use the facility equipment, please confirm the quantities in advance. NB: Some of the equipment may not function for your purposes on the day and quantities may change. We seek your understanding in advance.

● Fixtures list

Type	Location	Item	Quantity	Note
Table	Low table (Shared use for terrace seat)	White top board (outer edge - grain wood) Top board · Melamine dressing board (sheet pasting possible) Legs: Silver	30	W900×D900×H720 *10 Tables are stored as spares in warehouse
	High table	Wood grain Sheet pasting possible Legs: Black	12	W900×D900×H1,000 * 2 Tables are stored as spares in the warehouse
Chair	Indoor use	No armrests	60	W460×D510×H810 SH420
	Outdoor use	With armrests	40	W530×D510×H810 SH390
	High chair		30	W400×D460×H900 SH700
	Kids' chair		4	W455×D550×H790 SH425~570
Sofa set	Large	L type with back /armrests	2	W1,800×D850×H620 SH340
	Medium	I type with back	2	W1,600×D850×H620 SH340
	Small	No back	2	W850×D600×H340
	Exclusive table	*1 set each for a total of 2 sets	2	W1,200×D500×H370
Service counter	Integrated type	Built-in storage shelf separated type	1	W1,800×D700×H1,000
		(Storage rack)	2	
	Segmented type	Separable into three divisions	1	W1,800×D700×H1,000
Magazine / material shelf			1	*Planned purchase
Temporary stage		No decoration Step (Large) Step (Small) · box horse	3	W1,200×D2,400×H400

*hills café* / **SPACE**

Rules of Use

## Rules for Use of Hills Café/Space

### Hours of Use

Basic hours of use	8:00 ~ 23:00
Nighttime loading/set-up time	23:00 ~ 8:00
Nighttime removal/move-out	23:00 ~ 6:00
Extended off-hour use	Extended use available on a per-hour basis Refer to P007 for fees.

\*Hours of use include all time required for preparation and clean-up.

\*Refer to the venue fees on P007 for usage fees.

### Preliminary Meetings

1. Please meet with the Mori Building staff in charge at least 15 days prior to use to discuss details of event schedule, program, venue set-up, equipment and so on.
2. If use involves any construction within the venue, please confirm details in advance with the Mori Building staff in charge, including blueprints, preparatory drawings, electrical schematics and so on.
3. Depending on the nature of the event, management reserves the right to refuse use of the facilities, so work closely with the Mori Building staff in charge regarding preliminary meetings and site inspections.
4. Special security, cleaning and other requirements may be the responsibility of the user; please meet with the Mori Building staff in charge to discuss these in advance.

### Cancellations

In the event that the applicant initiates a cancellation, please submit the prescribed cancellation application form upon entering the required information.

### Cancellation Fee

Cancellation by 31 days prior to date of use	50% of venue fee listed on application form
Cancellation within 30 days of the date of use	Full venue fee listed on application form

### Cancellation after Contract Completion

In the event that any of the following conditions are true after completing the contract, we may revoke the user's permission to use the venue or halt the event while the facilities are in use. Note that the venue shall not bear any liability whatsoever for any damages caused to the user as a result of a cancellation for a reason that corresponds to any of the following.

1. If false information is entered in the application for use of the venue.
2. If using the facilities proves difficult due to a disaster or other instance of force majeure.
3. When a condition corresponding to any of the restrictions listed in the aforementioned Usage Restrictions is true.
4. When work or an event is conducted at a location unapproved for use.
5. When the user has failed to comply with the venue's Usage Restrictions.
6. If the usage fee has not been paid by the prescribed date.

### From Application to Contract and Payment

1. When applying, please indicate the purpose of the event, its nature and other details.
2. Please note in advance that, depending on the nature of the event, we may refuse use of the venue.
3. There is no system of tentative reservations. Only finalized applications are accepted.
4. Upon entering the required information on the venue's prescribed application form, please submit the document to a Mori Building Co., Ltd. official. We will make a decision after receiving your application.
5. Please pay a deposit (50% of basic usage fee of the venue) to the designated bank account by the venue within one week from submission of the application form. Please deposit the balance (50% of basic usage fee of the venue) by one week before the usage day.
6. Cancellations made after an application has been received will incur a separate predetermined cancellation fee.
7. Regarding overtime usage fee and other charges, after use of the venue,

an invoice will be issued based on the final statement. After you receive the invoice, please deposit money to the designated bank account within one month.

8. The applicant shall bear any wire transfer fees associated with their payment.
9. The right to use the venue may not be transferred or lent to another party.
10. If you are unable to comply with the Regulations for Use, your use of the venue may be refused even while you are using it.

### Usage Restrictions

We may refuse to rent out the venue in the event that any of the following conditions are true. Furthermore, use of the venue may be halted even if the application has been received and the facilities are in use. Mori Building Co., Ltd. shall not bear any liability whatsoever for any damages caused to the user as a result.

- The event goes against public order and morals.
- If false information is entered in the application for use of the venue.
- The event is connected to political, religious or other such activity.
- If a relevant government office issues an order to halt the event or it proves difficult to hold the event in compliance with a directive from such an office.
- If there is a risk of damage or destruction to the building or equipment.
- If there is a possibility that the event may create disorder or danger for visitors or the venue's surrounding area.
- If the Regulations for Use or the instructions of an administrator are not followed.
- Loud noises, foul odors or the like cause offense to the public.
- Traffic on the road in front of the venue is impeded.
- Events involving competition with Mori Building Co., Ltd. and Roppongi Hills.
- Events that may interfere with the business of Roppongi Hills tenants.
- Mori Building Co., Ltd. otherwise determines that the event is inappropriate.

### Notification to Relevant Government Offices

Depending on the nature of the event, notifications and applications may be required for submission to relevant government offices or elsewhere. With regard to notifications prescribed by laws, regulations and so forth, as well as the use of the venue and carrying out projects, the organizer should

notify the relevant government offices by the designated times and otherwise fulfill related requirements. However, there are certain forms for notifying the fire department, so please consult with one of our sales representatives prior to notification. In addition, when notifying relevant government offices and the like, please submit copies of notifications and application forms to the venue administrator.

Police	Azabu Police Station	03-3479-0110
Fire	Azabu Fire Station	03-3470-3470
Health Center	Minato Ward, Minato Health Center (Environmental Health Division)	03-5114-3009

**Administrative Liability**

With regard to accidents that occur while the venue is in use, the user shall be liable for not only the actions of the user, but also for all actions of business operators involved and of visitors. Hence, please do everything in your power to prevent accidents. Security for the venue and freight loading/unloading is the responsibility of the user. Please endeavor to control traffic, manage the situation in the venue, and prevent theft, fires, accidents and the like by consigning this work to a security contractor or stationing security personnel. For security, use the venue's designated security contractor(Shintei Security: 03-5909-8821).

**Exemptions and Compensation for Damages**

Mori Building Co., Ltd. shall not be liable whatsoever for any accidents in the facilities while they are in use, such as theft and damage. In the event that facilities, equipment, fixtures and the like are damaged or lost while the venue is in use, the user shall bear the costs.

**Administration of Restoration and Cleaning Work**

The user shall clean and restore the facilities used to their original condition. Mori Building Co., Ltd. shall verify the facilities' condition after their use. Note that if holding an event has an accompanying need for special cleaning, please use our designated contractor (Cleaning: Seishin Service 03-5786-9835)

Note:

1. Depending on use of media, etc. within Roppongi Hills, we may be

- unable to accept your application. Your understanding is appreciated.
2. Please give thorough consideration to neighboring tenants if any loud sounds, smells, long lines of people or the like will be present while holding your event.

**Rules Regarding Set-up and Removal**

As a rule, work time, including unloading and loading, shall be from 11 p.m. to 8 a.m.

Vehicles used for unloading and loading may use the car lift only between the hours of 11 p.m. and 5 a.m.

Vehicles involved in loading and unloading should exit from 66 Plaza by 5 a.m.

**Loading and Unloading**

1. Take the necessary precautions to avoid damaging or dirtying the facilities during loading and unloading.
2. When lanes for loading and unloading overlap with lanes for visitor traffic, please give visitors priority. Also, please station security guards at designated locations and give thorough consideration to safety.
3. You must go through procedures at the Distribution Center to use carts and other such equipment for loading and unloading.

**Setup and Removal Precautions**

1. Use of open flame, gas and electrical heating equipment, and bringing into the venue any hazardous materials is prohibited under fire prevention-related laws and regulations.
2. Adhesive tape, nails and the like may not come into direct contact with the building during installation work and may not be used on ceilings, floors, walls, windows. etc.
3. We may refuse to allow the production of loud noises, foul odors, shaking, etc.
4. Please consult with the venue administrator concerning the delivery of heavy items.
5. We may instruct you to only use fully flameproof materials (bearing a flameproof label) for ornamentation or display (including floor carpets, etc.).
6. Please ensure any decorative items remain at least 450mm from the ceiling.
7. Secure passage width of at least 2.5m in the space, and make sure that passage is accessible to at least two emergency exits.

8. Ensure displays and decorations do not interfere with sprinkler heads, etc.
9. Arrange ornaments and displays so that they do not obstruct light switches, emergency exits, fire doors, flameproof curtains, smoke ventilation equipment, fire alarms, breaker panel switches, shutters, shutter boxes, etc.
10. With regard to other rules, please comply with relevant laws and regulations.

**Work Notices and Loading/Unloading Procedures**

1. Building entry procedures are required for all workers involved in setup and removal, including the staff running an event.
2. Upon filling out the prescribed form, please submit the work notification to the venue administrator (to be received by 18:00 on the 3rd business day prior to the event).
3. Please apply in advance for use of the car elevator. The car lift operator must be trained in its use by the manufacturer.
4. Prior to beginning work on the day of, check in to the building at the Mori Tower Security Control Center .
5. All workers should wear a building pass. This is issued during building check-in, after confirming the construction work to be carried out that day.

**Loading and Unloading via the Distribution Center**

1. Unloading and loading involving use of loading docks on the B1 and B2 levels of the Mori Tower must all be arranged through the Distribution Center.
2. Submit an unscheduled loading/unloading registration to the Distribution Center.
3. When unloading items from the venue, bring the permit sent back by the Distribution Center.
4. Use of the logistics yard and wheeled hand truck rentals require a fee.
5. Roppongi Hills Logistics Management Center tel:03-6406-6688

**Running your Event**

1. Operating Manual

Please meet with the venue manager from the planning stage, in accordance with the operating manual that has been prepared.

We may request revisions to your operating plan at that time. Your cooperation is appreciated.

2. Event Staff

When running an event, all event staff should wear the staff IDs prepared for them. Please submit a sample staff ID in advance to the venue administrator.

3. Press activities

Media coverage and photography are prohibited without permission from Mori Building Co., Ltd. Please contact the Roppongi Hills Public Relations Office (Tel. 03-6406-6382) regarding any photography or coverage other than photos for documentary purposes. Please also contact the Roppongi Hills Public Relations Office prior to use of documentary photos in any other media.

4. Involvement of Celebrities, Cultural Figures and Other Notable Public Figures

You are required to submit an event timetable. For security reasons we may change the event plan or restrict lanes of traffic inside Toranomon Hills. Please liaise with the venue administrator in advance.

5. Contacts for Event Inquiries

At Roppongi Hills we generally do not respond to inquiries concerning events, so please arrange for the appropriate person or office anybody can contact specifically for your event.

**Precautions regarding use of car lift**

1. Application for use

If you wish to use the car lift for unloading and loading, please be sure to consult venue management in advance. Same-day applications for use are not accepted.

2. Car lift hours of use

As a rule, use of the car lift for unloading and loading shall take place between 11 p.m. and 5 a.m. All vehicles involved in unloading and loading should exit from 66 Plaza by 5 a.m.

3. Use of flatbed trucks prohibited

To prevent cargo shift, flatbed trucks not enclosed by panels may not be placed on the car lift.

4. Security and guidance

Security guards should be assigned during unloading and loading using the car lift. They should be posted in front of the car lift on the first floor (to guide pedestrians on the walkway) and at 66 Plaza (to guide pedestrians when vehicles are in transit).

\*Please make inquiries regarding and arrangements for security guards directly with Shintei Security (Shinjuku office, tel. 03-5909-8821), the

designated security company for Roppongi Hills.

5. On-site inspection of car lift

Please refer to the car lift dimensional diagram in the next section for car lift dimensions. Be sure to inspect the car lift on site in advance.

6. Car lift operation

The car lift is designed such that the driver raises and lowers the lift from inside. Other operation, including opening and closing of the lift doors and calling the lift require the operator to have received training from the manufacturer. Training is offered on the third Wednesday of each month from 10:30 a.m. Please contact the Mori Building staff in charge if you wish to receive training.

7. Wood deck protection

Vehicles traversing the wood deck when transiting 66 Plaza should provide protection for the decking section to ensure tire tracks are not left behind.

8. Stationary steering prohibited

Do not use stationary steering when moving vehicles.

9. Car lift dimensional diagram

\*Vehicle height limit is 3,000mm, with a weight restriction of 8,000kg when loaded.

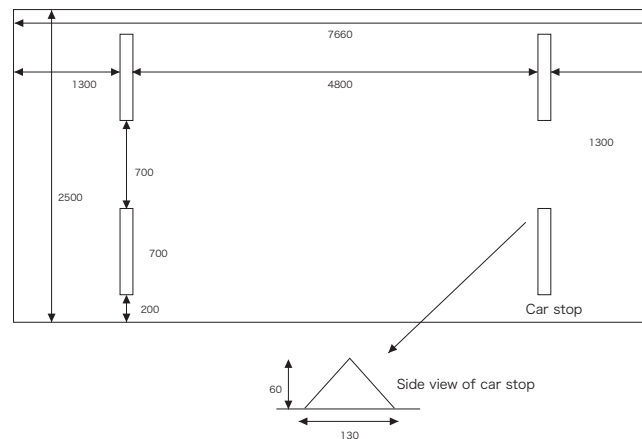

\*Use of the car lift requires an operator who has received training. Those who have not received training in the past are asked to participate in the simple training session prior to use.

**For inquiries on using the venue, contact**

Sales Planning Group, Town Management Department  
Mori Building Co., Ltd.  
Tel. 03-6406-6666